

BMC025. FM Drum.

Last updated 9-2-2014

*If you have any questions, or need help trouble shooting, please e-mail
Michael@Bartonmusicalcircuits.com*

I Features

II Schematics

- A. Input/Decay**
- B. VCO**
- C. VCA**
- D. Modulating Oscillator**
- E. Power Connections.**

III Construction

- A. Parts List**
- B. The Board**

I. Features

This is a new percussive sound module designed to make unnatural sounds not found in nature. It has two oscillators, one manually controlled and one voltage controlled. The manually controlled oscillator's output is used as a source of frequency modulation on the voltage controlled oscillator. The voltage controlled oscillator's output is then sent to an onboard VCA. The Voltage controlled oscillator can also be controlled with external control voltages, though it does not conform to the 1v/oct standard.

Both the modulating oscillator and VCO have both triangle and squarewave outputs and have switches to select which waveform is outputted.

II. Schematics.

The schematics for this module are presented in sub-circuits and then a master schematic is included at the end. It is easier to understand the circuit in chunks.

A. Input/Envelope Generator

This circuit produces the control voltage for the VCA circuit.

On the far left we see the wirepad marked "IN." A trigger or gate signal should be input here. The .01uf capacitor and 100K resistor to ground form a pulse shortener, making the pulse length of the input signal irrelevant. This is then input to an op-amp wired as a comparator. The output of the comparator goes to the decay section through a 1n4148 diode.

When the output goes high, current flows through this diode quickly charging the 1uf capacitor. The 220 ohm resistor and 500KA pot in parallel with the capacitor provide a path for the capacitor to discharge the voltage. The higher the resistance, the more slowly the capacitor discharge.

The capacitor is also connected to an op-amp wired as a buffer, which is outputting the capacitor's voltage onto the next stage, as well as lighting up an LED indicator. The output goes to the VCA.

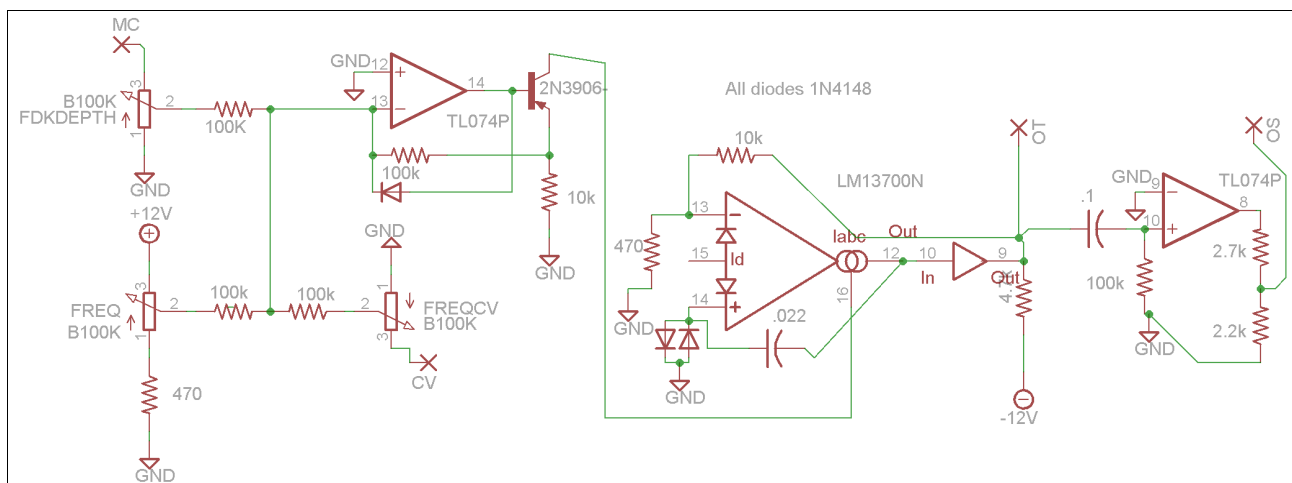
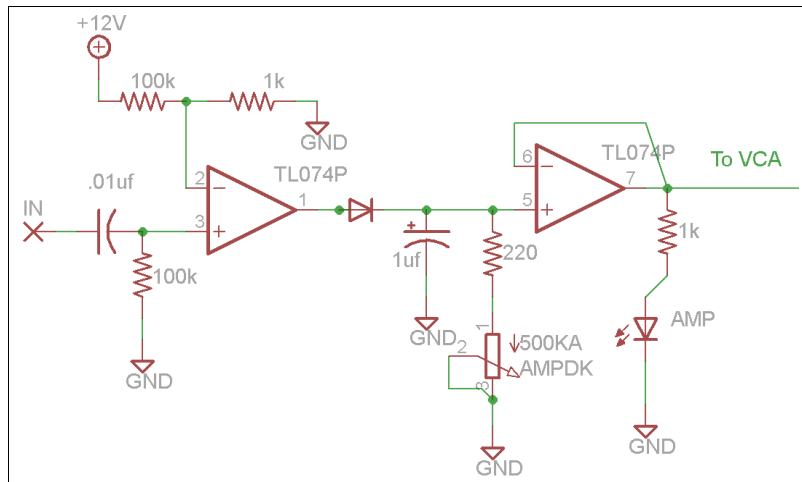

B.VCO

On the far left we see the controls for the three knobs determining frequency and modulation. Each control is a 100K linear resistor wired as an attenuator. At the top left is the wirepad for the center of the modulation waveshape switch, "MC," below this is the baseline

frequency control and to the right is the frequency CV input.

These voltages are summed together on the negative input of the op amp wired in conjunction with a 2N3906 to form a linear voltage controlled current source.

This current source is controlling the current of one half of an LM13700 OTA wired as a VCO. The design for the VCO is taken from the LM13700 datasheet. The OTA is forming an Integrator/Schmitt Trigger type oscillator by itself.

The output of the LM13700 is sent to wirepad "OT" this stands for "Output-Triangle." The signal then goes through a .1uf capacitor to get rid of DC offset and is then sent through a comparator and two resistors wired as a voltage divider to produce a clean square wave output that goes to wirepad "OS" or "Output-Square."

IF BUILDING FOR +/-15V replace the 10K resistor in the feedback path of the OTA with a 15K. Replace the 2.7k/2.2K resistors with 2.2k/1k. These resistors are marked in the board image later in the documentation.

C. VCA

On the bottom we see the output of the envelope generator. A single 2n3906 in series with a 10k resistor forms the current control. The VCA's input is connected to the output waveform selector switch's center post, the wirepad is marked

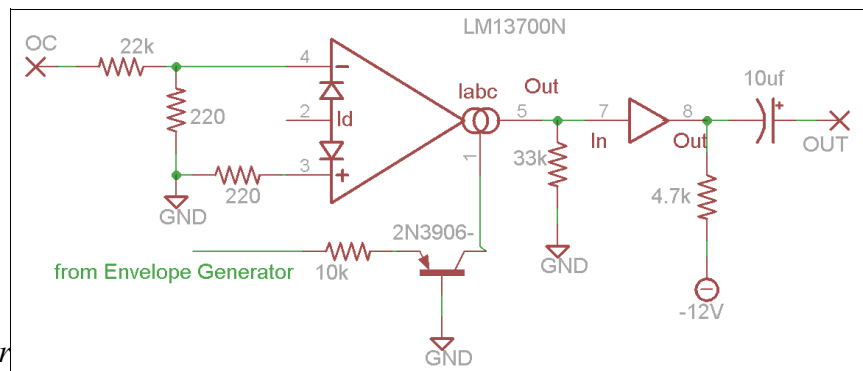

"OC." This VCA is incredibly simple, the signal is input to the inverting input through a 22K and 220 ohm resistor voltage divider used to limit the signal on the input. The output of the VCA goes through the onboard buffer and then a 10uf capacitor to decouple the DC bias.

D. Modulating Oscillator

The op-amp on the left is an inverting schmitt trigger, whenever the voltage input to it from the 100K resistor goes beyond +/-5V the output of the schmitt trigger goes either positive or negative depending on polarity of the input. This output goes first to the

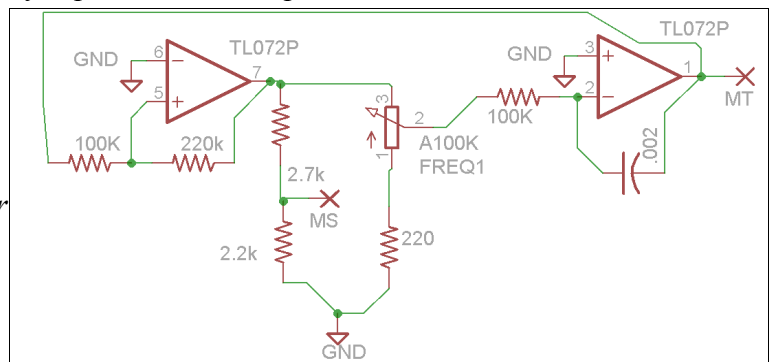

square wave output marked "MS" through a voltage divider (the schmitt trigger outputs +/-12V, these resistors attenuate it down to +/-5V). It then goes through a pot resisting the flow of current into the integrator, the 220 ohm resistor between the pot and ground sets the minimum frequency.

The integrator is the other op-amp, current from the schmitt trigger charges or discharges the capacitor in the op-amps feedback loop. The output of the integrator goes to the input of the schmitt trigger and to the "Modulation-Triangle" wirepad which is connected to the wave select switch for the modulator.

NOTE FOR +/-15V BUILDERS: The parts values presented in the schematic are for a +/-12V system. When building for +/-15V the 220K in the schmitt trigger's feedback path should be increased to a 330K. The 2.7K/2.2K voltage divider should be replaced with a 2.2K/1K voltage divider, and the 100K resistor between the pot's wiper and the integrator should be increased to 150K. In the Construction section, these parts are marked on the board.

E. Power Supply

Here we see the two power connectors for MOTM and Eurorack style systems. The supply is filtered by a 10 ohm resistor and 10uf capacitor, and then .01uf decoupling capacitors are placed near the power supply pins of the ICs.

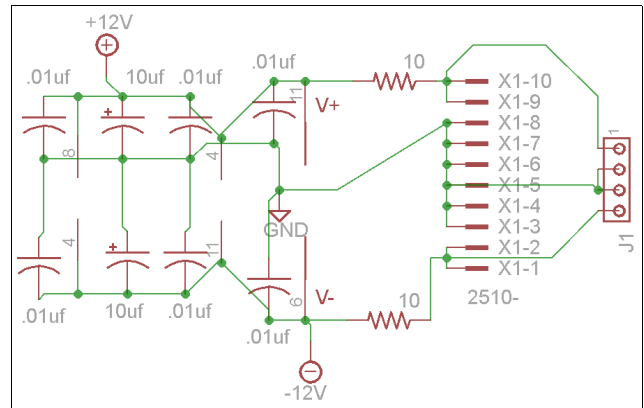

III. Construction

A. Parts List

Semiconductors

Value/Name	Quantity	Notes
TL072	1	or similar dual op-amp
TL074	1	or similar quad op-amp
LM13700	1	or 13600
2N3906	2	
1n4148	4	
LED	1	3mm size

Resistors (if building for a 15v system, see below for alternate list)

Value/Name	Quantity	Notes
10 ohm	2	1/4W metal film for all resistors
220 ohm	4	
470 ohm	2	
1K	2	
2.2K	2	
2.7K	2	
4.7K	2	
10K	3	
22k	1	
33k	1	
100K	9	
220K	1	
A500K Pot	1	16mm PC mounted, logarithmic taper
A100K Pot	1	16mm PC mounted, logarithmic taper
B100K Pot	3	16mm PC mounted, Linear taper

Capacitors

Value/Name	Quantity	Notes

<i>.01uf</i>	<i>7</i>	<i>cheap ceramic disk.</i>
<i>.002uf</i>	<i>1</i>	<i>Poly box type.</i>
<i>0.02uf</i>	<i>1</i>	<i>Poly box type</i>
<i>.1uf</i>	<i>1</i>	<i>Poly box type.</i>
<i>1uf</i>	<i>1</i>	<i>Electroyltic</i>
<i>10uf</i>	<i>3</i>	<i>Electrolytic</i>

OTHER

<i>Name/Value</i>	<i>Quantity</i>	<i>Notes</i>
<i>8 pin socket</i>	<i>1</i>	<i>DIP socket</i>
<i>14 pin socket</i>	<i>1</i>	<i>DIP socket</i>
<i>16 pin socket</i>	<i>1</i>	<i>DIP socket</i>
<i>Power connecter</i>	<i>1</i>	<i>either Euro or MOTM depending on your system</i>
<i>SPDT toggle</i>	<i>2</i>	<i>panel mount, ON-ON type</i>
<i>Jack</i>	<i>3</i>	<i>either 1/4" or 1/8" depending on your system</i>

ALTERNATE RESISTOR LIST FOR 15V

<i>Value/Name</i>	<i>Quantity</i>	<i>Notes</i>
<i>10 ohm</i>	<i>2</i>	<i>1/4W metal film for all resistors</i>
<i>220 ohm</i>	<i>4</i>	
<i>470 ohm</i>	<i>2</i>	
<i>1K</i>	<i>4</i>	
<i>2.2K</i>	<i>2</i>	
<i>4.7K</i>	<i>2</i>	
<i>10K</i>	<i>2</i>	
<i>15K</i>	<i>1</i>	
<i>22k</i>	<i>1</i>	
<i>33k</i>	<i>1</i>	
<i>100K</i>	<i>8</i>	
<i>150K</i>	<i>1</i>	
<i>330K</i>	<i>1</i>	
<i>A500K Pot</i>	<i>1</i>	<i>16mm PC mounted, logarithmic taper</i>
<i>A100K Pot</i>	<i>1</i>	<i>16mm PC mounted, logarithmic taper</i>
<i>B100K Pot</i>	<i>3</i>	<i>16mm PC mounted, Linear taper</i>

B. The Board

To the right is an image of the PCB for this project. The PCB is 100mm x 41mm. The mounting holes are spaced 96mm x 23mm apart. The pots are spaced 21.59mm apart.

There are 9 wirepads on the PCB, they should be connected as follows.

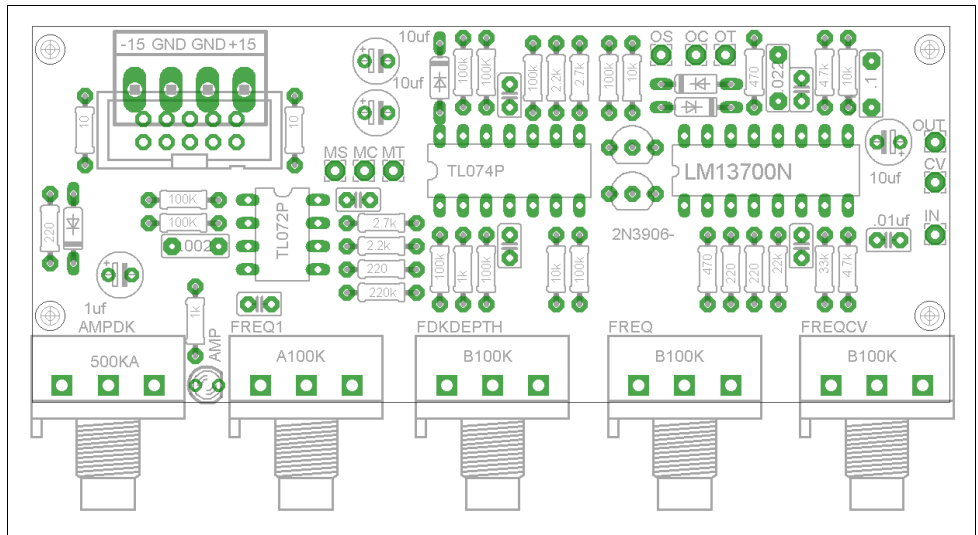

Jacks:

IN - tip of the input jack

CV - tip of the CV jack

OUT - tip of the output jack and switch of the CV jack to allow self modulation

Modulation Waveform Selection switch:

MS - Top lug of switch

MC - Center lug of switch

MT - Bottom lug of switch

Output Waveform Selection Switch:

OS - Top lug of switch

OC - Center lug of switch

OT - Bottom lug of switch

For a ground connection, use the center wirepad of whichever power supply you're not using.

For +/-15V builders

All the yellow resistors have had their values changed in this image to correspond to a 15V system. I encourage you to stuff these resistors first, to avoid later confusion.

