

CV Arpeggiator Rev 2.1 Build Documentation.

Last updated 8/31/2019

The CV Arpeggiator is a modular synth project used for creating arpeggios of control voltage. It utilizes a custom programmed PIC 16F685 micro controller. It includes an internal voltage controlled clock. There is an optional expansion PCB which allows use of external control voltage and finer control of notes in the arpeggios.

I The Chip

- A. Pin-out
- B. Functional Descriptions
 - 1.Note Generator Functions
 - 2.Internal Clock/Divider Functions

II The PCBs

- A.Schematic/summary of IC1 and surrounding circuitry.
- B.Schematic/summary of Output circuitry.
- C.Schematic/summary of CV input circuitry.
- D.Schematic/summary of Power Supply circuitry.
- E.Schematic/summary of Clock Input circuitry
- F.Schematic/summary of The Expansion PCB's Circuitry
- G.Board Layouts and physical information.
- H.Parts List.

III Calibration

I. The Chip

Section A - Pin-out.

Diagram 1:

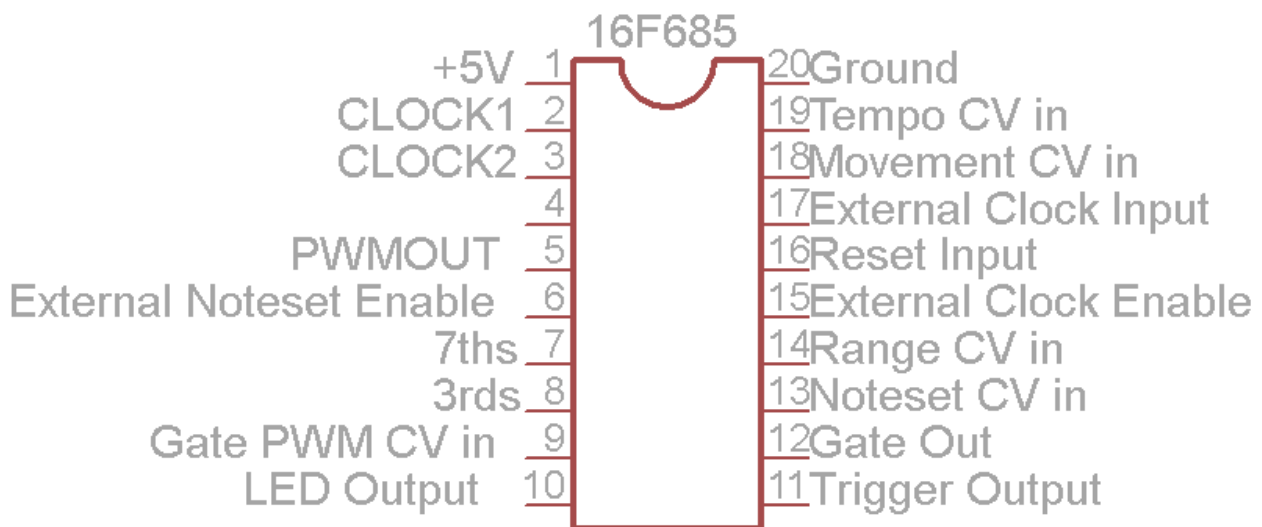

Pins 9, 13, 14, 18 and 19 are used as CV inputs. DC voltages between 0 and +5V are used to control various parameters of the chip. These pins should be connected to a voltage source and decoupling caps connected to ground.

Pins 10, 11 and 12 are digital outputs, these toggle between 0 and +5V. These pins should be connected to build out resistors.

Pins 6, 7, 8, 15, 16 and 17 are digital inputs, which respond to pulses and toggles between 0 +5V. These pins should be connected to a voltage source and either pull-up or pull-down resistors.

Pin 5 is the pulse width modulator output, which in this circuit is used as a digital to analog converter. It is connected to a low pass filter.

Pins 2 and 3 are connected to a 20mhz crystal oscillator, which provides a time reference for the micro-controller.

Pins 1 and 20 connect the chip to the power supply. A decoupling cap should be placed between them.

Section B. Functional Descriptions

1. Note Generator Functions.

The note generator portion of the chip is controlled via 2 events and 3 parameters. These parameters and events control the output of the PIC's PWM which when filtered through a low-pass filter result in Arpeggiated control voltages

The two events which control the note generator are:

1.Clock Events

2.Reset Events

Clock events control when the note generator changes notes. These come from the internal clock/divider or an external clock.

Reset events control when the note generator goes back to the root note of the arpeggio. These can only be inputted from an external source. A +5V pulse on pin 16 causes a reset.

The three parameters which control the note generator are:

1.Range

2.Movement

3.Note set

Range limits the number of octaves the note generator can use. The following table displays what voltage ranges inputted to pin 14 will result in what range of octaves.

Voltage Inputted	Range
0-1V	1 octave range
1.1V - 2V	2 octave range
2.1V-3V	3 octave range
3.1V-4V	4 octave range
4.1V-5V	5 Octave range

Movement controls how the note generator moves through the note set; whether to generate the top or bottom note of a note set after a reset event and how to react when reaching the bottom or top. It also has a "random" function. The following table displays the various modes of movement available at what voltages on pin 18.

Voltage	Name	On Reset Goes to	At End of Note set
0-.7V	Up/Down	Bottom of note set	Reverses direction
.8-1.4V	Up Repeating	Bottom of note set	Goes back to bottom
1.5-2.1V	Down Repeating	Top of note set	Goes back to top of note set
2.2-2.8V	Pendulum	Bottom of note set	Holds note for 1 extra clock event at end, then reverses direction, on both bottom and top.
2.9-3.5V	Up and stay	Bottom of note set	Holds note until reset
3.6-4.2V	Down and stay	Top of note set	Holds note until reset.
4.2-5V	Random	Random note	n/a

Note set refers to the musical notes contained in the arpeggio. Unlike the range and movement parameters, which are controlled exclusively by voltages, note set can be controlled either by a voltage exclusively or a voltage and a pair of digital inputs. A third digital input on pin 6 is used to change between methods of controlling note set. Wiring pads for the digital inputs are on the expansion board.

When pin 6 is held at 0V, a voltage is used exclusively to control note set, the following table shows what note sets are available at what voltages on pin 13.

Voltage	Root	Minor 3rd	Major 3rd	5th	Minor 7th	Major 7th
0-.6V	Yes	No	Yes	Yes	No	No
.6-1.2V	Yes	Yes	No	Yes	No	No
1.2-1.9V	Yes	No	Yes	Yes	No	Yes
2.0-2.5V	Yes	Yes	No	Yes	Yes	No
2.6-3.1V	Yes	No	Yes	No	No	Yes
3.1-3.8V	Yes	Yes	No	No	Yes	No
3.9V-4.4V	Yes	No	No	Yes	No	No
4.5V-5V	Yes	No	No	No	No	N

When pin 6 is held at +5V, pins 7 and 8 are used in conjunction with the voltage on pin 13. When pin 7 is held at +5V the 3rd in the note set is major, when held at 0V the 3rd in the note set is minor. Pin 8 controls the 7ths using the same logic. The following table shows what base note sets are used depending on what voltage is on pin 13.

Voltage	Root	3rd	5th	7th
0-.6V	Yes	Yes	Yes	No
.6-1.2V	Yes	Yes	No	No
1.2-1.9V	Yes	Yes	Yes	Yes
2.0-2.5V	Yes	Yes	No	Yes
2.6-3.1V	Yes	No	Yes	Yes
3.1-3.8V	Yes	No	No	Yes
3.9V-4.4V	Yes	No	Yes	No
4.5V-5V	Yes	No	No	No

So, when pin 7 is held at +5V, pin 8 is held at 0V and a voltage of 1.6 is present on pin 13, it will result in an note set of Root, Major 3rd, 5th and Minor 7th; also known as a dominant 7th chord.

2.Internal Clock/Divider Functions.

To generate clock events for the note generator an internal clock or divider is used. When Pin 15 is held at +5V the internal clock is used, when held at 0V the internal divider is used.

The internal clock has three hardware outputs and two parameters.

The three hardware outputs are

1.Trigger

2.Gate

3.Indicator LED

The two parameters are:

1.Tempo

2.Gate PWM

Trigger outputs a +5V pulse on pin 11 lasting roughly 5ms whenever the clock generates a new note event.

Gate outputs a +5V pulse on pin 12 whenever the clock generates a new note event, the duration of the pulse is dependent on the gate PWM parameter or gate length parameter.

Indicator LED outputs a +5V pulse on pin 10 in unison with the Gate output.

Tempo controls the rate at which note events are generated. A voltage on pin 19 controls the tempo.

Gate PWM controls the pulse width of the gate/LED. A voltage on pin 9 sets the PWM. The length of the gate is determined by the voltage on pin 9 and the period (amount of time between clock events) of the clock. If .5V were inputted on pin 9, and the tempo had been set to a period of 100ms, the resulting gate length would be 10ms. If 2.5V was present on pin 9 with the same tempo the gate length would be 50ms.

The internal divider shares the same outputs as the internal clock, but the 2 parameters are replaced and an event is added.

The new parameters are:

1.Division.

2.Gate Length

The new event is the **external clock**. When a +5V pulse is inputted to pin 17 this causes an external clock event.

Division determines how many external clock events it takes to cause a clock event. A voltage on pin 19 selects the division rate. The following table shows what voltages result in what division rates.

Voltage	Divide by
0-.6V	1
.6-1.2V	2
1.2-1.9V	3
2.0-2.5V	4
2.6-3.1V	8
3.1-3.8V	16
3.9V-4.4V	32
4.5V-5V	64

Gate Length determines the actual amount of time a gate pulse lasts. It is not dependent on any other parameters, only the voltage on pin 9.

II The PCB

A. Schematic/Summary of IC1 and Surrounding Circuitry

Diagram 2:

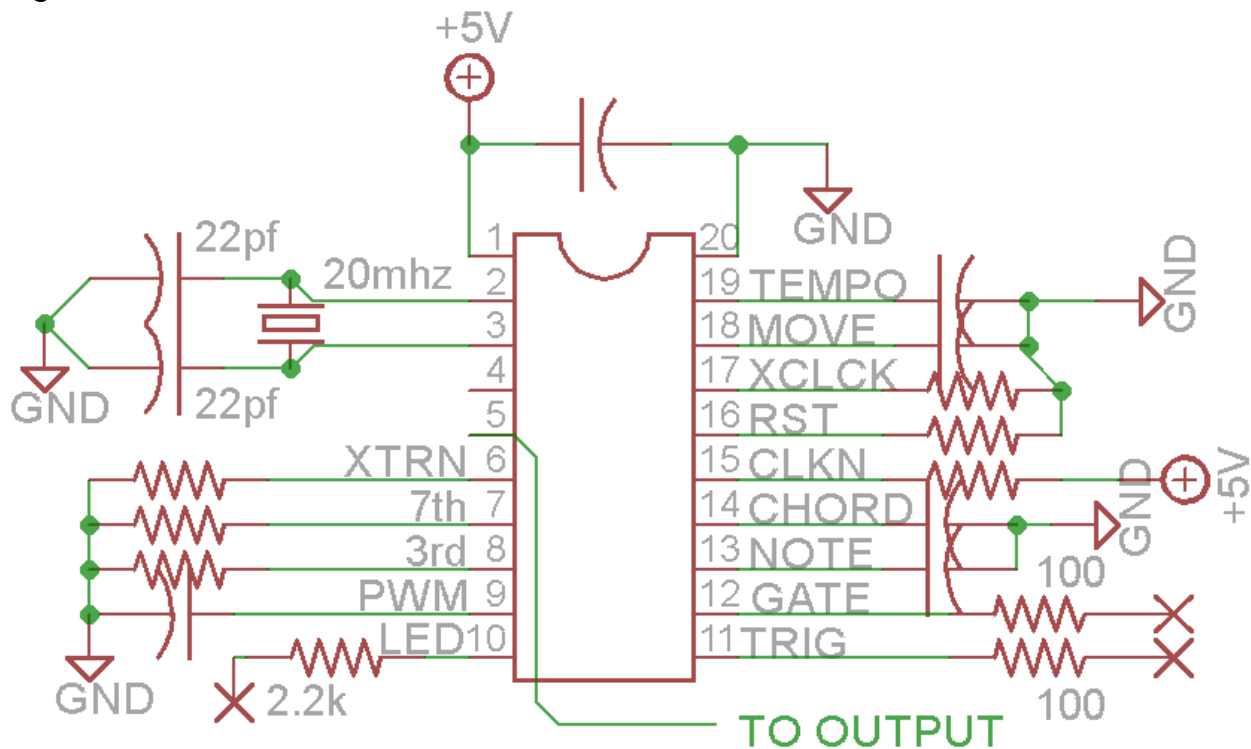

Unlabeled Resistors are 100K

Unlabeled Capacitors are .1uf (value not critical)

The PIC is supplied power through pin 1 and a ground reference is established through pin 20. A 20MHz crystal oscillator provides an internal timing reference for the chip, it connects to pins 2 and 3, which are also connected to 22pf caps to ground which stabilize the oscillator.

All of the analog input pins (9, 13, 14, 18 and 19) have .1uf decoupling caps to ground which stabilize the control voltages. These pins are also connected to the expander header.

The digital inputs on pins 6, 7, 8, 16 and 17 have 100k pull-down resistors connected to ground. These keep the pins at 0V until a positive pulse is inputted from the wiring pads. Digital input pin 15 uses a 100k pull-up resistor connected to +5V, this leaves the internal clock normally on, until the wiring pad is connected to ground.

The digital outputs on pins 11 and 12 have 100 ohm build-out resistors in addition to wiring pads. The digital output on pin 10 uses a 2.2K current limiting resistor, though a different value can be used to adjust brightness of the LED. The wiring pad is intended to be connected to the anode (positive terminal) of an LED while the cathode is connected off board to ground.

B. Schematic/Summary of Output Circuitry

Diagram 3:

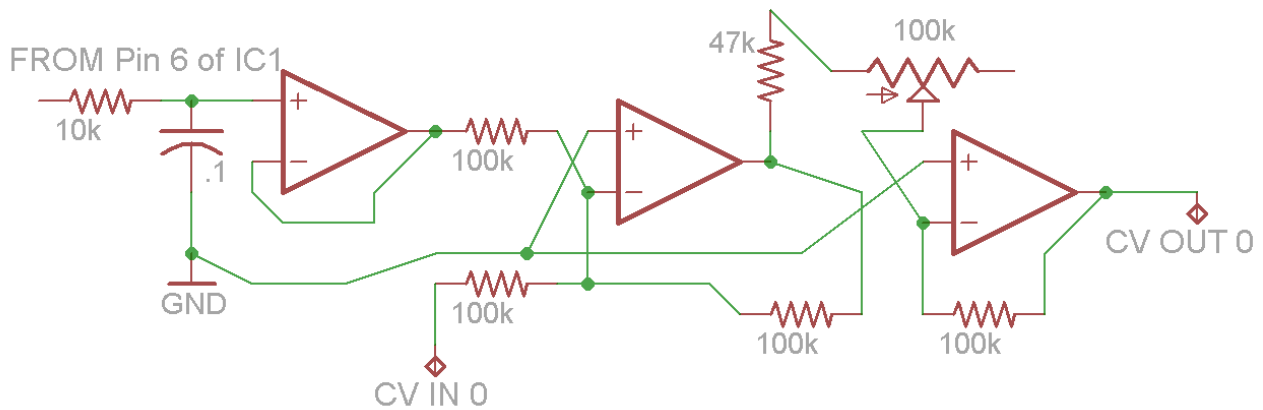

The PWM output from the micro-controller is filtered by the 10K resistor and the .1uF capacitor to ground, and then buffered by the first op-amp.

The next op amp acts as an inverting voltage summer. The voltage inputted at CV IN 0 is summed with the filtered output from IC1.

The final op-amp is an inverting gain stage. The trim pot should be adjusted so that the voltage outputted at wiring pad CV Out 0 is +5V when no voltage is inputted on CV IN 0 and the range pot is set to full rotation and movement is set to "up and stay" mode.

As a word of warning, because the final voltage is the sum of the output of IC1 and whatever is inputted at CV IN 0, output voltage can potentially be as high as +15V, so be careful with what you connect the circuit to.

C. Schematic/Summary of CV inputs.

Diagram 4:

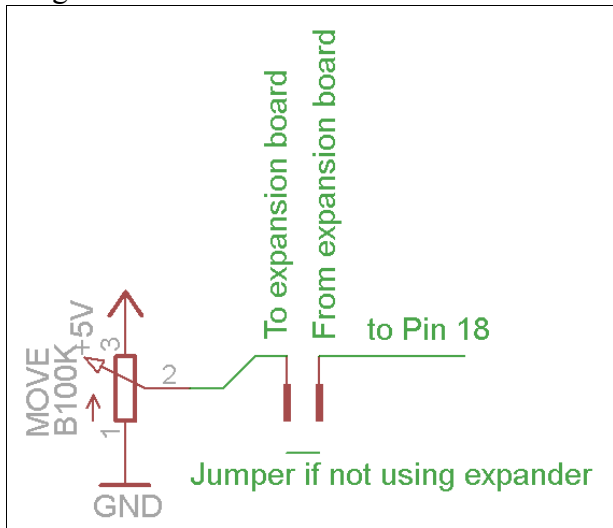

This is repeated five times, once for each of the voltage controlled parameters. A 100K linear pot is wired as a voltage divider between +5V and ground. The output of this pot is sent to a pin on a 14pin DIP connector. When not using the expansion PCB, this pin should be jumpered to the adjacent pin, and the pot will directly control that parameter. If using the expansion PCB, the voltage will be mixed with an external control voltage.

D.Schematic/Summary of Power Supply

Diagram 6:

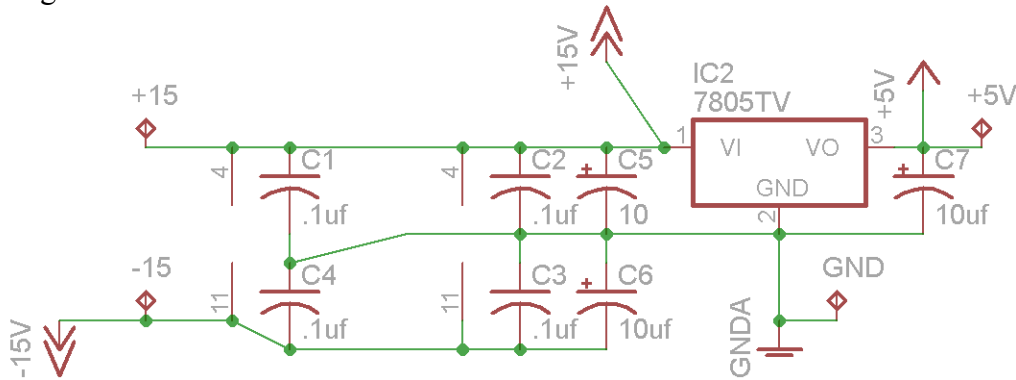

The power supply is connected to the supply rails of the modular case through either an MOTM or Eurorack style connector. The +15V supply is then fed into a voltage regulator to produce the +5V supply. The +/-15V rails and +5V rails are filtered by 10uF electrolytic filter caps. The two quad op-amp ICS also have decoupling .1uF capacitors near the supply pins on each IC. There are additional wire pads for +5V and GND supplies for connecting with off board components.

E. Schematic/Summary for Clock Input

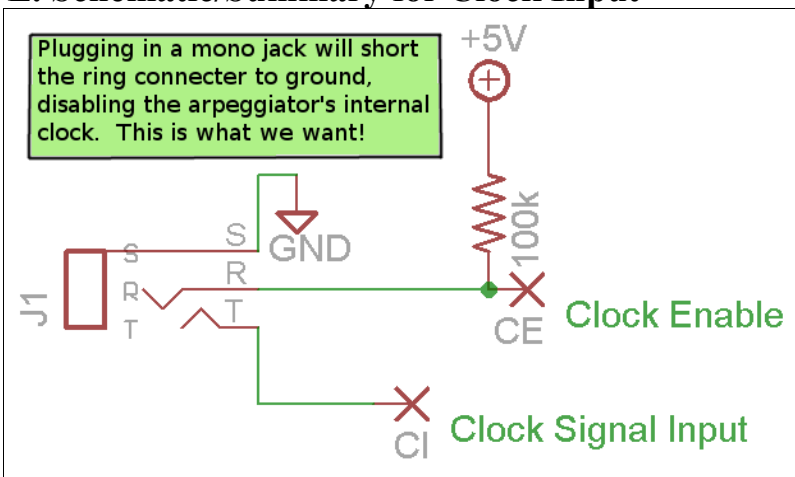

This shows in detail how the clock input jack works. When nothing is plugged in, the internal clock is enabled by being connected to +5V. When a mono jack is plugged in, the sleeve of the jack shorts the enable pin to ground and the internal clock is disabled so that the external clock can be clearly heard.

F.Schematic/Summary of Expansion Board

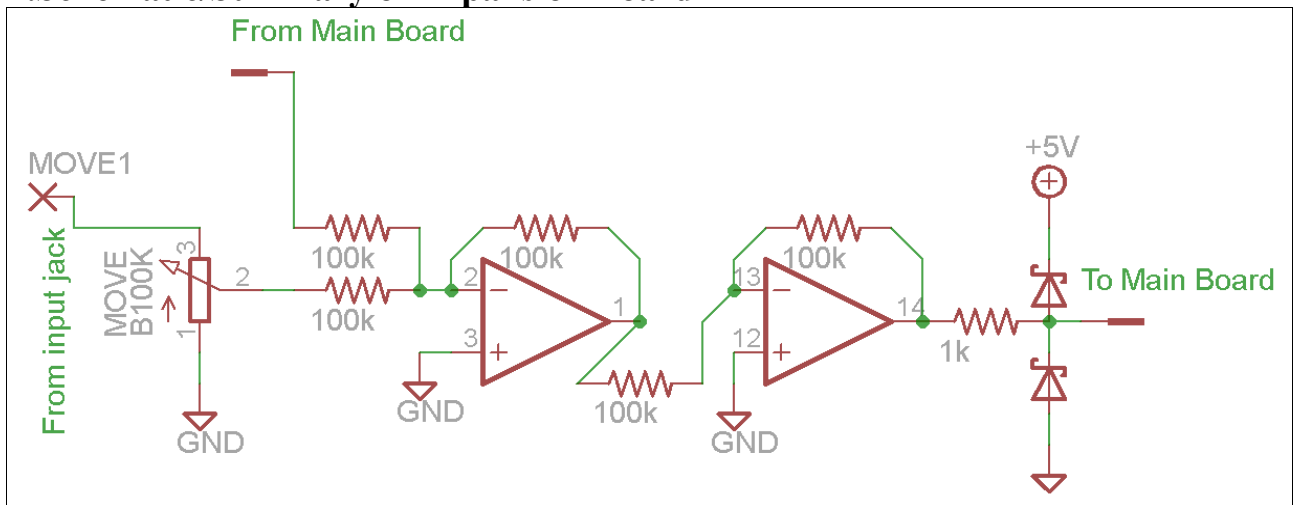

This circuit is repeated 5 times. On the left is a wiring pad where an external control voltage is inputted and then attenuated with a 100k pot. This attenuated CV is then mixed with the fixed

CV from the main board by the two op-amps. Finally on the right is a 1K resistor and two schottky type diodes, these are used for over-voltage/under-voltage protection. The voltage is then sent to the pins of the PIC.

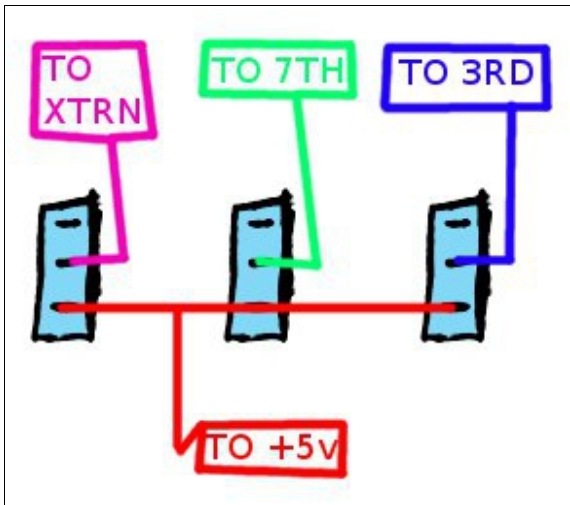

In addition to the voltage processing, the expansion board also has wiring pads for using switches to select major and minor chords. These switches should be wired like in the diagram on the left. I like to use clipped resistor leads to wire busses between switches like this.

The connector between the expansion board and the main board's pinout is diagrammed on the right.

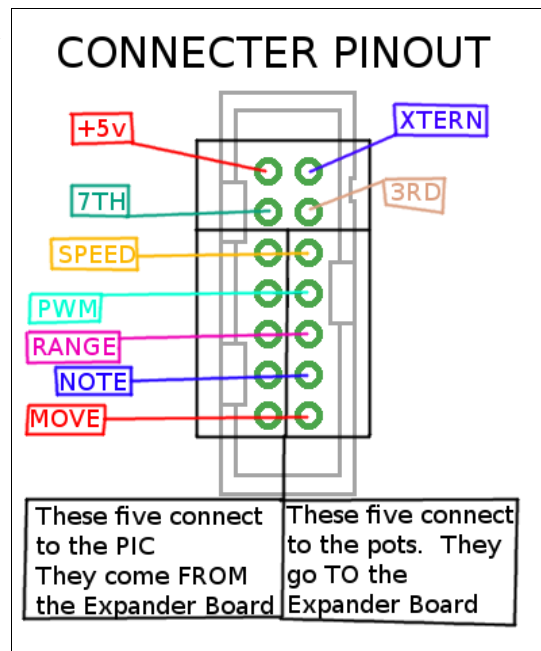

G.Board Layouts and Physical Information.

Main Board

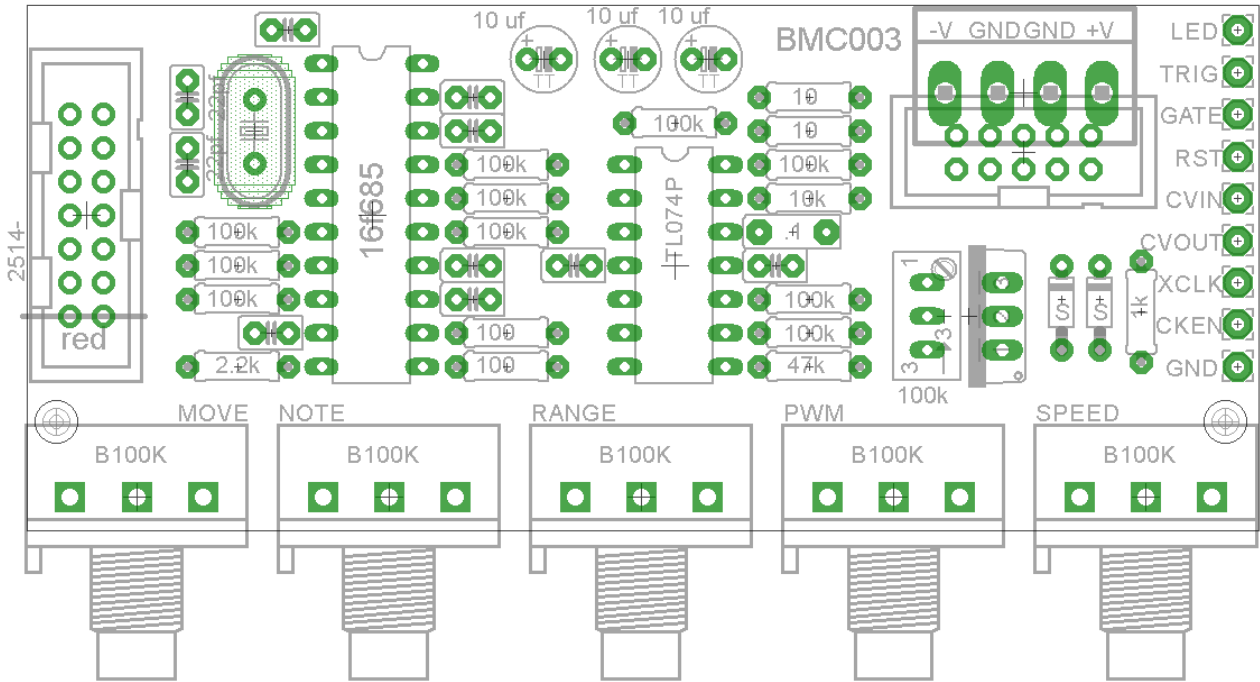

The main board's dimensions are 94mm x 40mm. The pots are spaced at 3/4"

Expansion Board

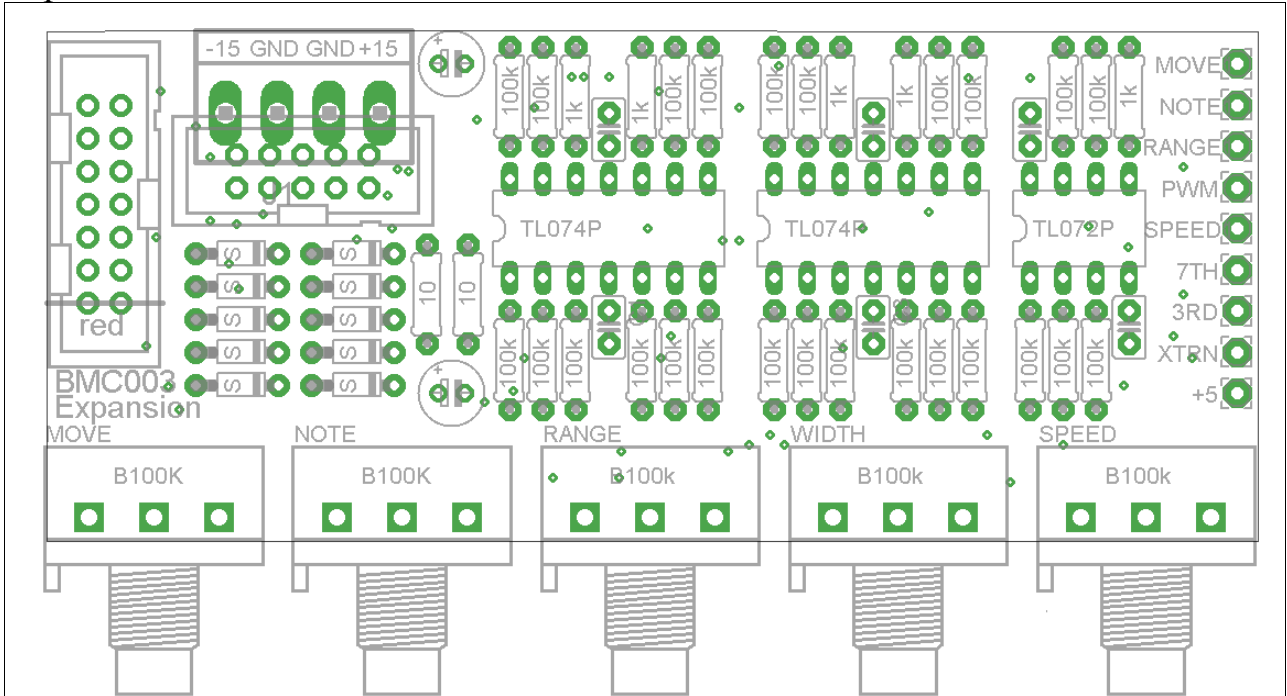

The expansion board's dimensions are 94mm x 40mm. The pots are spaced at 3/4"

Below is a photo of a wired main Arpeggiator board. This is the same one pictured on www.bartonmusicalcircuits.com/arp/. The leftmost jack is the Clock Input jack. “XCLK” is wired to the tip, while “CKEN” is wired to the switch, and “GND” is wired to the sleeve.

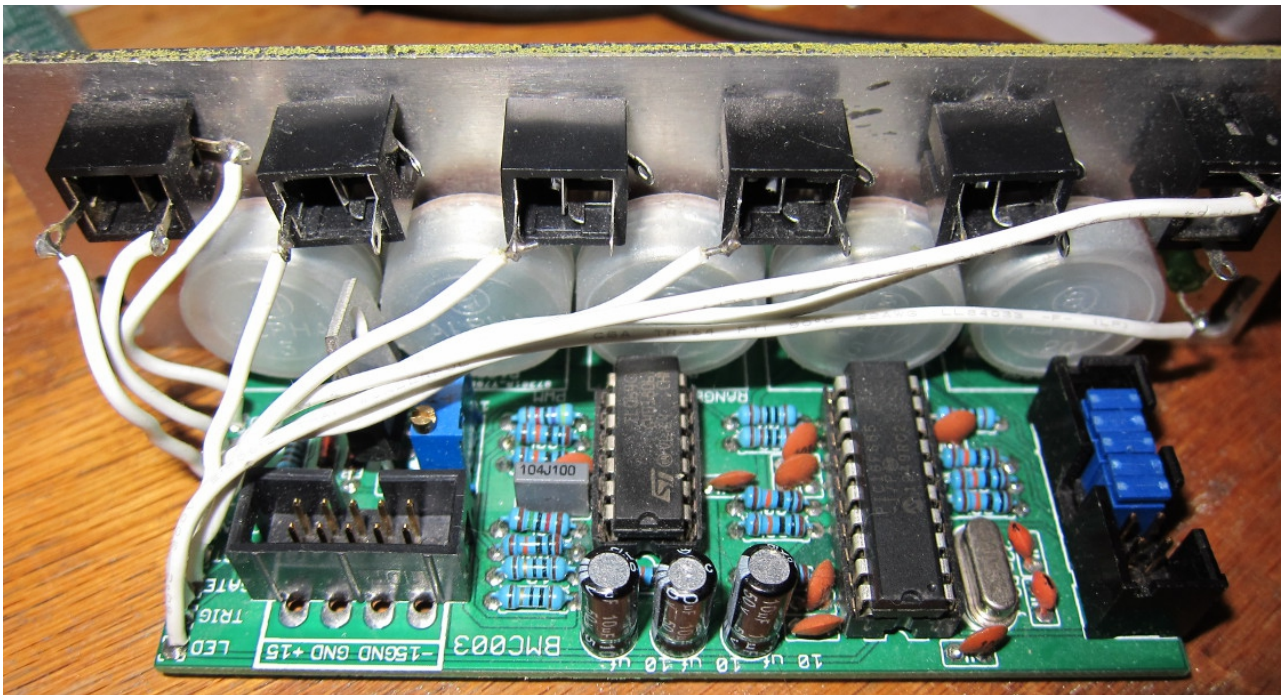

Below is the wiring for the Expander Module. +5V is bussed along the bottom of the switches.

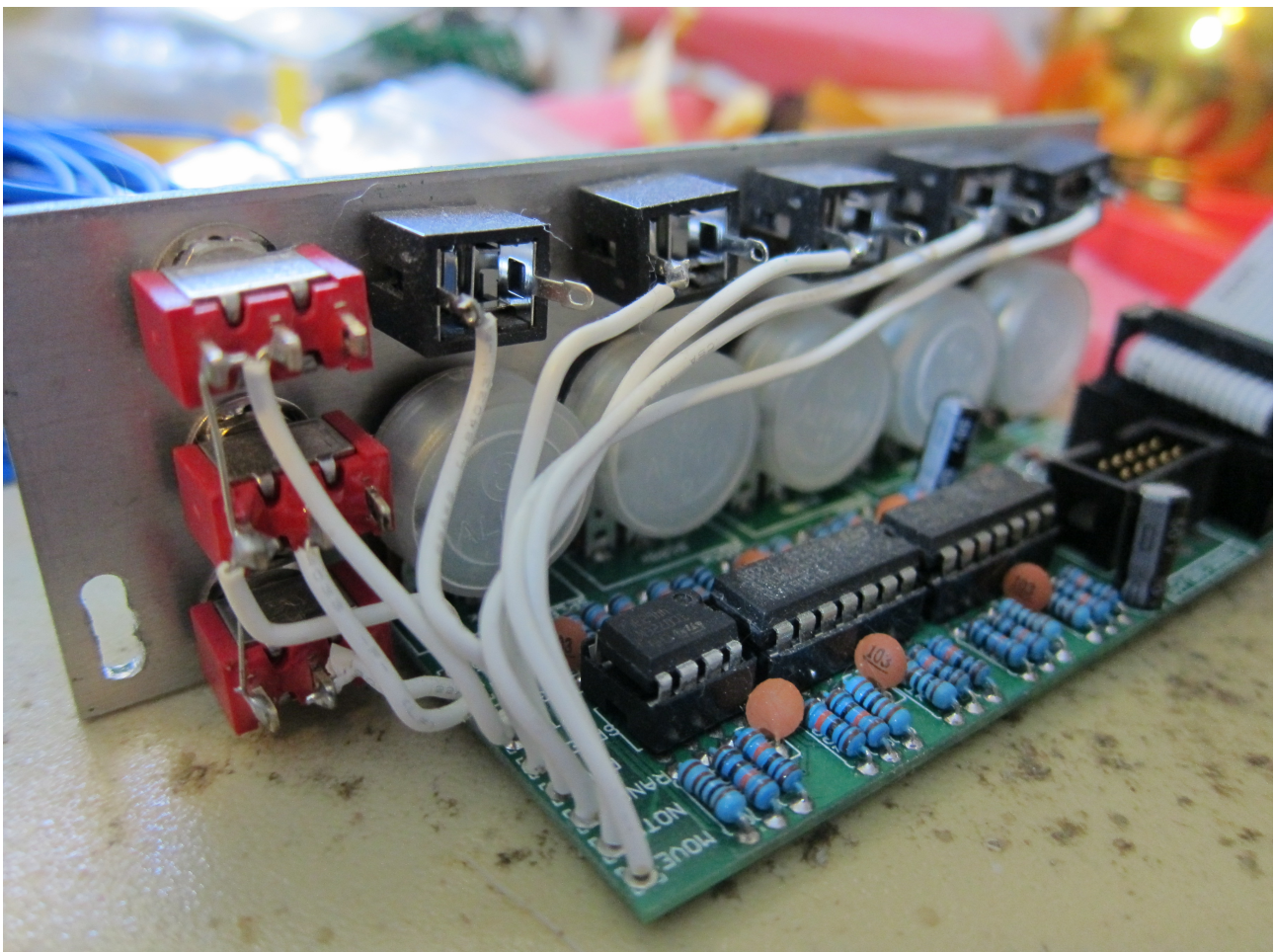

H. Bill of Materials.

Main Board

Semiconductors

Value	Qty	Notes
PIC16f685	1	Should have come with your PCB
TL074	1	
Schottky Diodes	2	SD101C, 1N914 or similar
7805 Voltage Regulatr	1	TO220 Package
20mhz Crstyal Oscillator	1	5mm lead spacing

Resistors

Value	Qty	Notes
10 ohm	2	7.5mm lead spacing on all resistors unless noted otherwise
100 ohm	2	
1k	1	
2.2k	1	
10k	1	
47k	1	
100k	10	
100k Trimpot	1	
Linear 100k Pot	5	PC Mounted 16mm

Capacitors

Value	Qty	Notes
22pf	2	Ceramic disk. 2.5mm lead spacing
.01uf	8	Ceramic disk. 2.5mm lead spacing.
0.1	1	Boxed Poly. 5mm lead spacing
10uf electrolytic	3	

Connectors

Value	Qty	Notes
14pin DIP Socket	1	
20pin DIP socket	1	
Power Connector	1	Either MOTM or Eurorack
14pin DIP headers	1	(only if planning on using the expander, these connections can be permanantly jumpered together if not)
2pin header jumper	5	For using main board without expander.

Off Board Parts

Value	Qty	Notes
-------	-----	-------

Mono Jack	5	
Stereo Jack	1	
LED	1	

EXPANSION BOARD

Semiconductors

Value	Qty	Notes
TL074	2	
TL072	1	
Schottky Diode	10	SD101c, 1N914 or similar

Resistors

Value	Qty	Notes
10 ohm	2	All resistors 7.5mm lead spacing unless noted
1K	5	
100K	25	
100K linear pot	5	PC Mounted 16MM

Capacitors

Value	Qty	Notes
.01 uf	6	ceramic disk, 2.5mm lead spacing
10uf capacitor	2	electrolytic

Connectors

Value	Qty	Notes
14pin DIP socket	2	
8pin DIP socket	1	
14pin DIP header	1	
Power Connector	1	

Off Board

Value	Qty	Notes
Mono Jack	5	
SPST or SPDT	3	

III. Calibration.

1.If using just the main board, put jumpers between the headers on the 5 rows of pins closest to the pots. If using the expander board, use an IDC connector to connect the two 14 pin headers together between the boards.

2.On the main board, turn the "Note" knob all the way up and the range knob all the way up, and feed the CV output to a VCO's 1v/oct input. Adjust the trimpot on the main board until the octaves sound correct. Check your work with a voltmeter, fine tune if necessary.

For questions or help troubleshooting, please e-mail Michael@Bartonmusicalcircuits.com