

BMC053. 4 Quadrant Multiplier And Panner REVISION 2

Last updated February 26 2022

If you have any questions, or need help trouble shooting, please e-mail
Michael@Bartonmusicalcircuits.com

I Overview/Controls/Inputs/Outputs

II Schematic

III Construction

A.Parts List

B.The PCB

C.Wiring

D.Callibration

REVISION CHANGES:

1. Replaced DIP package 13700 with SMD package
2. Resistor value changes to increase input impedance of VCA cells

[Previous Revision's Documentation Here](#)

I. Overview/Controls/Inputs/Outputs

A. Overview – This module uses VCAs arranged in a particular way to achieve two outcomes, a voltage controlled panner and a four-quadrant multiplier. The signal flow is illustrated to the right. The triangles with circles on the end represent inverters.

If you're unfamiliar with a four-quadrant multiplier, it's a specialized VCA where negative control voltage causes the output to invert. The quadrants are mapped out in the diagram below.

To achieve 4QM, the audio input is sent to two VCAs. The MOD input controls the positive VCA and an inverted MOD controls the negative VCA. The negative VCA's output is then inverted and mixed with the positive output.

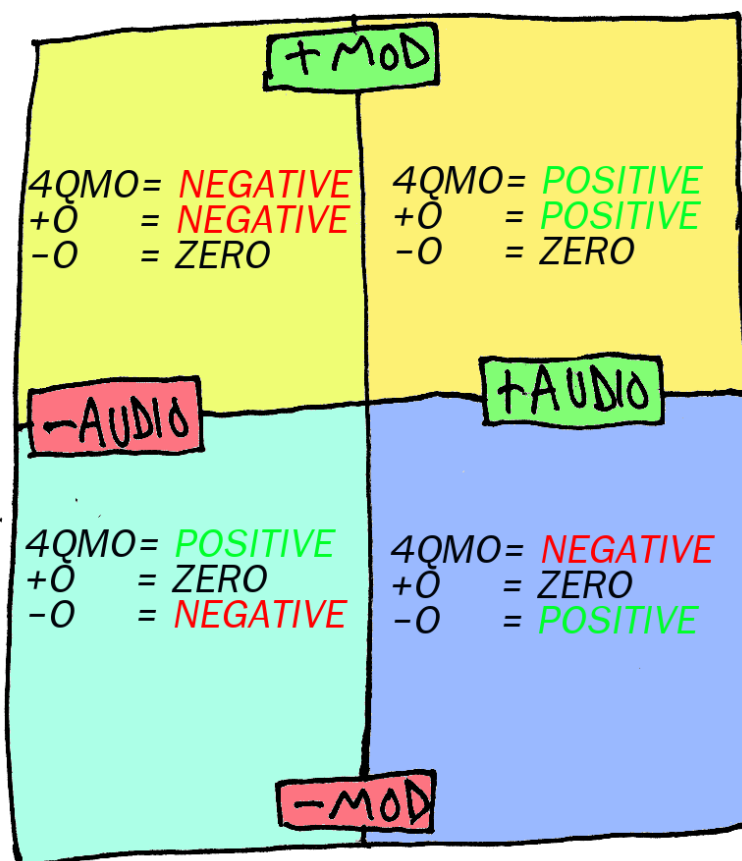
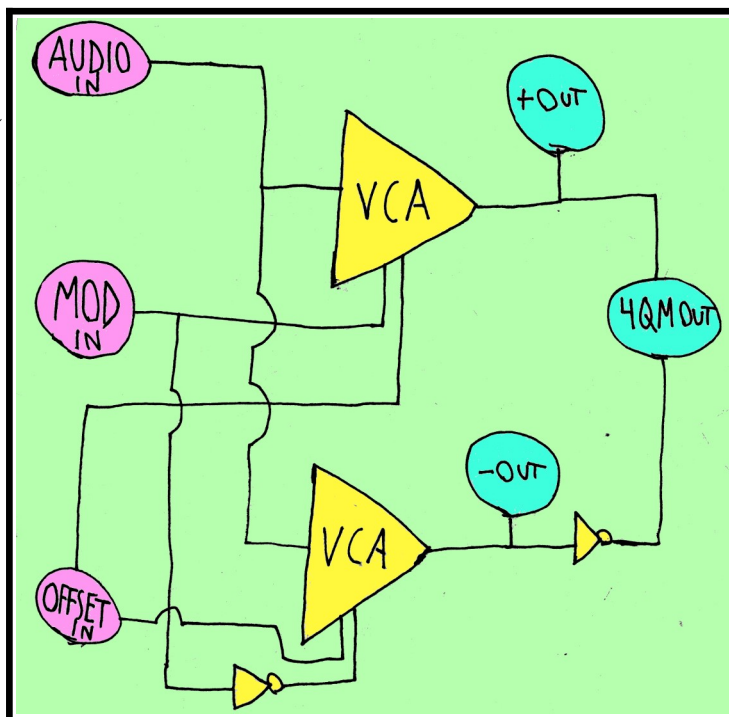

B. CONTROLS/INS/OUTS

1. Audio Input – This is the signal that will be attenuated/inverted by the 4QMP. It does not have to be an audio signal. There is an attenuator for this input.

2. Mod Input – This signal controls the attenuation/inversion of the 4QM output and controls whether the +O or -O is active. There is an attenuator for this input.

3. Offset Input – This signal will be summed with the mod input and inverted mod input in controlling the VCAs. Its effect on the 4QM output is negligible when working properly, but when using the module as a panner, it keeps a channel from turning all the way off when the MOD polarity changes.

4. AC Switches – These toggles bypass decoupling capacitors in the circuit controlling whether the MOD and AUDIO inputs are DC or AC coupled.

5. -O Output – This output is active

when the MOD input goes negative, the more negative the greater the signal.

6. +O Output – This output is active when the MOD input goes positive, the more positive the greater the signal.

7. 4QMO Output – This is the 4 Quadrant Multiplier Output.

II. Schematic.

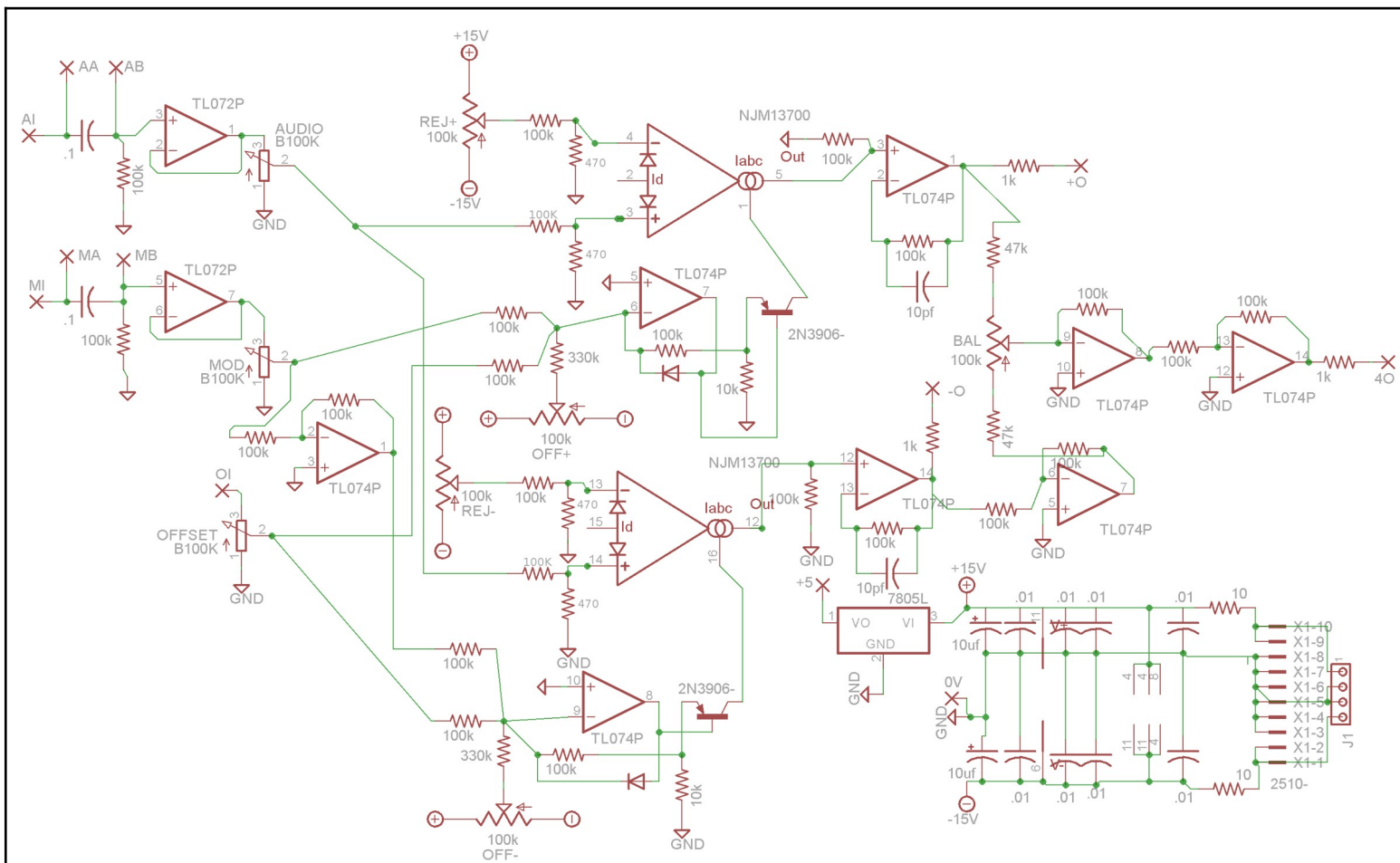

Above is the schematic for this PCB. Even though “+15V” and “-15V” labels are on power symbols, this module is compatible with either 12V or 15V systems without any parts substitutions. In the upper left of the diagram are the Audio and MOD input wirepads AI and MI, each is in series with a .1uF decoupling capacitor that can be bypassed by a toggle, marked by wirepads AA, AB, MA and MB. A 100k resistor to ground centers the AC coupled voltage at ground. Op-amps buffer these inputs before going to attenuator potentiometers.

The audio input is then connected to the audio inputs of the VCAs. The VCAs are based on Thomas Henry's VCA-1 which you can read about the operations of here: http://www.birhofsynth.com/Thomas_Henry/Pages/VCA-1.html The mod input is split after being buffered, one going to the CV summing for the positive VCA and the other being inverted by an op-amp and then sent to the CV summing for the negative VCA. The Offset input is attenuated by its knob and then sent the CV summing of each VCA.

The outputs of the VCAs are connected to their respective outputs through 1k current limiting resistors. The negative VCA's output is then sent to an inverter. The inverted negative output is then mixed with the positive output. A balance trimpot is used in the voltage summing to make the summing precise. A pair of op-amps wired as inverting gain stages mix the outputs together.

The power connections are in the bottom right of the schematic. PCB footprints for Eurorack and MOTM power connectors are in parallel with each other. A 10ohm/10UF low pass filter filters the negative and positive power rails. The ICs are all connected to these rails. The power pins of each IC are also filtered with a small capacitor to ground to clean up any noise on the power rail. A 5V supply for normalizing the OFFSET knob is provided by the 7805L regulator.

III. Construction

A.Parts List

Semiconductors

Name	Quantity	Notes
13700	1	16pin SMT package
TL074	2	14pin DIP package
TL072	1	8pin DIP package
7805L	1	TO-92 package
2N3906	2	TO-92 package
1N4148	2	Or other small switching diode

Resistors

Name/Value	Quantity	Notes
10 ohm	2	1/4w metal Film for all resistors unless otherwise noted
470 ohm	4	
1K ohm	3	
10K ohm	2	
47K ohm	2	
100K ohm	23	
330K	2	
B100K Pots PC Mounted	3	16 mm Alpha linear taper, PC Mounted. Like this.
100K Cermet trimmer	5	3296 package

Capacitors

Name/Value	Quantity	Notes
10pf	2	Ceramic disc.
.01uf	6	Ceramic disc. Value not critical
.1uf	2	Polyester Film Box type.
10uf	2	Electrolytic, at least 16V rating.

Other

Name/Value	Quantity	Notes
Power connecter	1	Eurorack or MOTM
Toggle switch	2	SPDT. Like this.
Switching Jack	1	
Mono Jack	5	Switching jack will work as mono jack
Knobs	3	
14 pin DIP socket	2	

B. The PCB

The PCB is 67x60mm. The mounting holes are spaced 24.765mm apart and pots are spaced 25.4mm apart. To the right are images of the PCB with and without traces.

C. Wiring

Wiring is very simple for this project. The Offset jack should be a switching jack and the rest can be mono or switching. The wirepads should be attached to the following points:

- 1.AB – To the top terminal of the Audio AC toggle.
- 2.AA – To the middle terminal of the Audio AC toggle.
- 3.MB – To the top terminal of the Mod AC toggle.
- 4.MA – To the middle terminal of the Mod AC toggle.
- 5.MI – To the tip connector of the Mod in jack.
- 6.AI – To the tip connector of the Audio in jack.
- 7.OI – To the tip connector of the Offset in jack.
- 8.+O – To the tip connector of the Positive output jack.
- 9.-O – To the tip connector of the Negative output jack.
- 10.4O – To the tip connector of the 4QM Output jack.
- 11.+5 – To the switch of the Offset in Jack.
- 12.0V – To the sleeve connector of any jack. If using a non-conductive panel or jacks whose sleeves are isolated from the panel, you should then connect all sleeves together.

D. Calibration

- 1.Input a square wave from a VCO to the MOD in. Turn the MOD in pot up and turn the AUDIO in and OFFSET in pots all the way down. Adjust the REJ+ trimmer until there is as little signal as possible at the +O output, then adjust the REJ- trimmer until there is as little signal as possible at the -O jack.
- 2.Input a signal into the Audio Input jack. Turn the audio input pot up and turn the MOD in and OFFSET in pots all the way down. Adjust the OFF+ trimmer until there is no signal on +O output, then repeat with OFF- and the -O output.
- 3.With signal still in the Audio jack and the audio pot turned up and the MOD pot still turned down, slowly turn up the OFFSET pot until you start to hear something. Adjust the BAL trimmer until you hear nothing.

